

Tie Downs

**“HARDWARE
for HARD WEAR”**

10-44 TIE DOWN (ANCHOR POINT)

- Steel construction/zinc finish
- Drain holes
- 360° base rotation
- ✓ Available without mounting holes
- ✓ Available without drain holes
- ★ See page 85 for capacity rating

A.L. HANSEN MFG. CO.
PATENT



F10-44XXZNXX

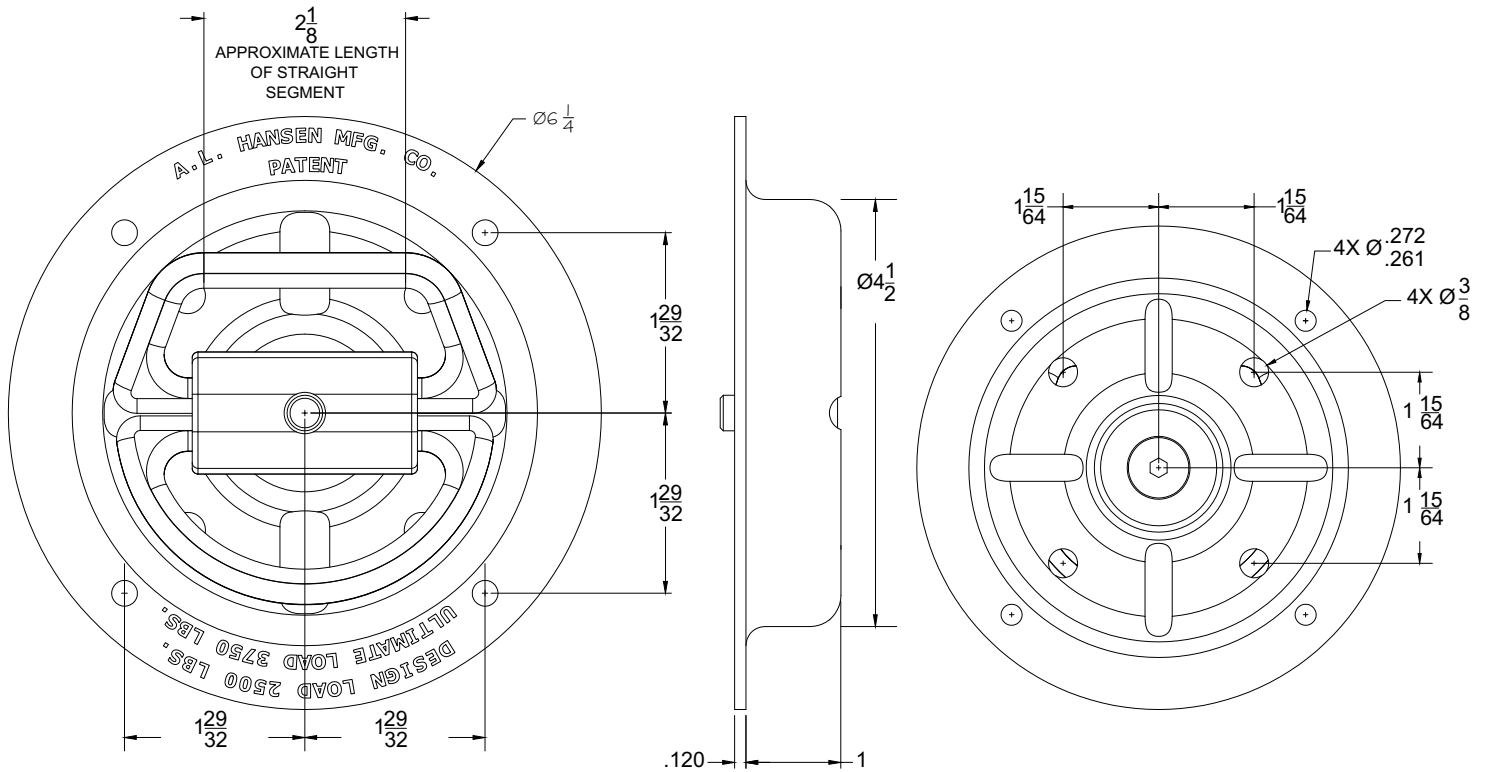

**A. L. HANSEN
MANUFACTURING**

701 Pershing Rd. Waukegan, Illinois 60085 U.S.A. Phone: (847)244-8900 Fax: (847)244-7222 WWW.ALHANSEN.COM

ISO 9001:2000
QUALITY SYSTEM



Approvals
Quality System Registration

TIE DOWN CAPACITY CHART

CATALOG PAGE NO.	PART DESCRIPTION	BREAK STRENGTH CAPACITY* (LBS)	WLL* WORKING LOAD LIMIT (LBS)
86	10-39 SHACKLE / BASE IN RECESSED CUP	6000	2000
86	10-40 SHACKLE / BASE IN RECESSED CUP	6000	2000
87	10-44 SHACKLE / BASE IN RECESSED CUP	2500	830
88	10-50 SHACKLE / BASE IN RECESSED CUP	30000	10000
89	239-L WIDE FLANGE TIE-DOWN	5000	1665
89	239-S TIE-DOWN	2000	665
90	300-C RING & CLAMP	1500	500
90	300-L RING & CLAMP	1500	500
90	300-S RING & CLAMP	1500	500
91	300-SP RING & CLAMP	1500	500
91	300-U RING & CLAMP	1200	400
92	300-F FLUSH MOUNT TIE DOWN	1500	500
92	39-F TIE-DOWN WITH SPACER	1200	400
93	39 TIE-DOWN	1200	400
93	39-AP TIE-DOWN	1200	400

Note: Unless otherwise specified, all ratings are based on a straight (static) tensile pull. Load direction other than straight may result in a significant reduction in breaking strength capacity.

***Rating Parameters:** To provide a reliability factor to manufacturers for the differences between static testing and dynamic (real world) loading on load securement components, rating parameters have been established. Breaking Strength Capacity is the maximum load that an assembly will withstand before failing. Working Load Limit (WLL) is defined as the maximum load that a component or assembly should receive during regular use. WLL is typically calculated as one-third (1/3) of Breaking Strength Capacity. (CVSA/FHWA out of service criteria) A working knowledge of the breaking strength capacity & working load limit (WLL) in securement assemblies is necessary to properly securing a load.

Maintenance: The normal usage of tie down assemblies subjects them to wear and deterioration which can reduce the breaking strength capacity. It is recommended that all assemblies be regularly inspected.

Any worn, deformed, misused, or overloaded assemblies should be replaced immediately.

Warning: Do not modify or alter products- The modification and/or alteration of any component or assembly may cause serious injury or death.

All A. L. Hansen Mfg. Co. products should be used in accordance with local, state, federal and industrial regulations. The amount, type, capacity, and location of tie down assemblies used in securing cargo is the responsibility of the buyer. Suitability for application is the responsibility of the buyer.

**A. L. HANSEN
MANUFACTURING**

701 Pershing Rd. Waukegan, Illinois 60085 U.S.A. Phone: (847)244-8900 Fax: (847)244-7222 WWW.ALHANSEN.COM

ISO 9001:2000
QUALITY SYSTEM



Approvals
Quality System Registration